



DockLaser Project Consortium
c/o Center of Maritime Technologies e.V.
Bramfelder Str. 164
D-22305 Hamburg
Phone +49 40 691 9947

Press Release
Hamburg, 03.02.2004

Development of Mobile Laser Processing Equipment presented

Industrial User Group of the "DockLaser" Project meets

First results of the European Union funded "DockLaser" project have been presented at a workshop in Halle / Germany end of December 2003. The project, which aims at the development of mobile laser processing equipment for difficult accessible areas in shipbuilding, has a total budget of 4 MEUR for the period between September 2002 and August 2005. Under the leadership of German shipbuilder Jos. L. Meyer, Papenburg several shipyards (IZAR – Spain, Odense Steel Shipyard – Denmark), research institutes (Welding Institutes from Rostock and Halle, Germany, FORCE – Denmark, VUZ Bratislava – Slovakia), equipment manufacturers (Fronius – Austria, MobileLaserTec – Germany, Intelligent Welding Automation – Denmark) and a classification society (Det Norske Veritas – Norway) joined forces to increase productivity and product quality in the block and final assembly areas of complex vessels.

The equipment concept developed by DockLaser foresees a movable base station which accommodates a high power solid state laser as well as the appropriate peripheral equipment. The base station can be connected to mobile devices for welding of long joints, for tack welding as well as for manual welding and cutting in outfitting areas. The maximum distance between the base station and the tools can reach up to 50 metres which gives sufficient flexibility for an efficient application in the assembly of large structures.

The focus of the first project phase was put on the establishment and evaluation of end-user requirements as well as on the definition of welding parameters in laboratory tests. As a next step, the integration of the equipment components has started beginning of 2004 in Rostock, Germany. The third year of the DockLaser project will be dedicated to practical tests in the participating shipyards leading to the approval of the technology by the classification society.

The results of first welding tests as well as the equipment concept have been presented at the workshop in Halle to a wider community of industrial users. In view of current results and the vast experiences of the consortium the participants of the workshop were positive, that the project goals will be reached. The project will thus contribute to introducing laser technology to new fields of application and to strengthen the competitiveness of the European shipbuilding industry.

In order to promote a wide industrial application of the project results as well as to ensure practical relevance, the DockLaser consortium has established an "Industrial User Group". Membership in this group is open for industrial companies who gain access to the project results against payment of an annual fee. User Group members are encouraged to discuss the project procedures and to adopt the work programme to better fit their practical

needs. Current member companies of the DockLaser Industrial User Group are: Nordseewerke Emden - Germany, BEA Systems – United Kingdom and IMG – Ingenieurtechnik und Maschinenbau GmbH - Germany. The consortium invites all interested companies to join its efforts and join the User Group. Detailed information can be found on the project homepage at www.docklaser.com.

The DockLaser consortium is supported by the Center of Maritime Technologies e.V., Hamburg and BALance Technology Consulting, Bremen.

Hamburg, February 2004

Contact:

Coordinator of the DockLaser Project:

Jos. L. Meyer GmbH
Dipl.-Ing. Guido Pethan
Phone: +49 4961 815 046
Fax +49 4961 814 497
Mail: pethan@meyerwerft.de

Coordinator of the Industrial User Group:

Center of Maritime Technologies e.V.
Dr. Frank Roland
Phone: +49 40 691 99 47
Fax: +49 40 691 99 73
Mail: cmt.roland@t-online.de

Pictures from the workshop:

(Files can be ordered from cmt.roland@t-online.de)



Figure 1 Workshop participants

From left: Dr. Ahlers, BALance; Mr. Pantekoek, Nordseewerke; Mr. Pethan, Meyer Werft; Mr. Neubert, SLV Halle; Mr. Drobek, IMG; Mr. Lohne, DNV; Dr. Nokleby, DNV; Mr. Theile, Nordseewerke; Mr. Jasnau, SLV Mecklenburg-Vorpommern.

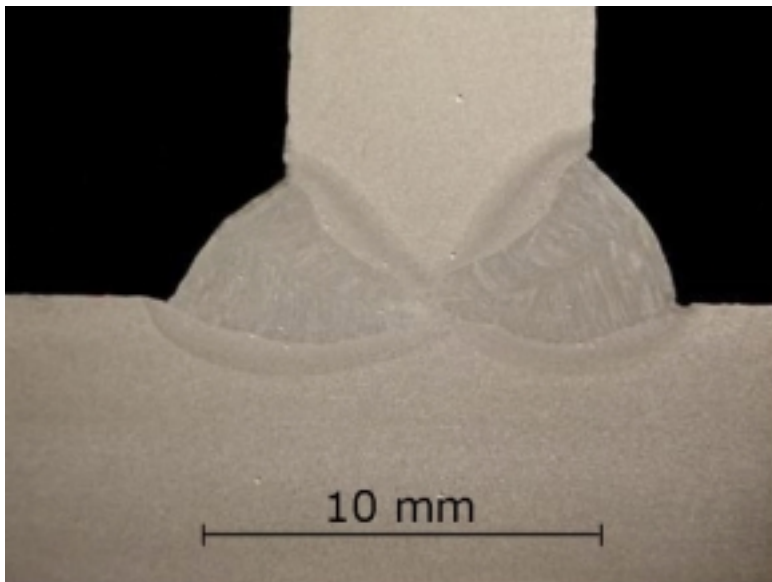

Figure 2: DockLaser test weld: T-joints full penetration
(Profile thickness 8mm, Nd-YAG-Laser, Power 4,2 kW, Welding speed 2 m/min)
Source: SLV Mecklenburg-Vorpommern

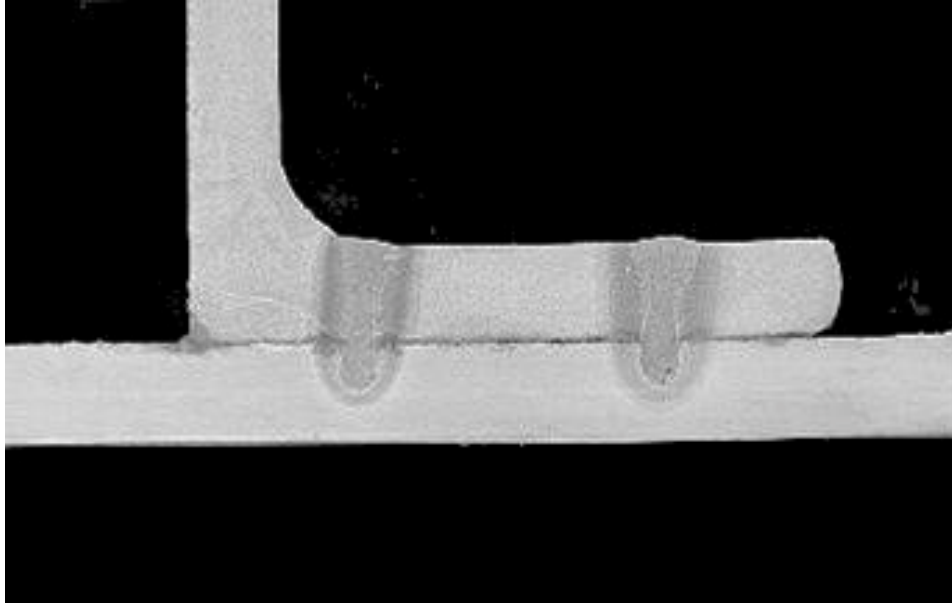

Figure 3: Example for manual hand guided overlapping welds to connect an angle profile (attachment) (Laser power 2,5 kW, Welding speed 0,6 m/min)
Source: SLV Mecklenburg-Vorpommern

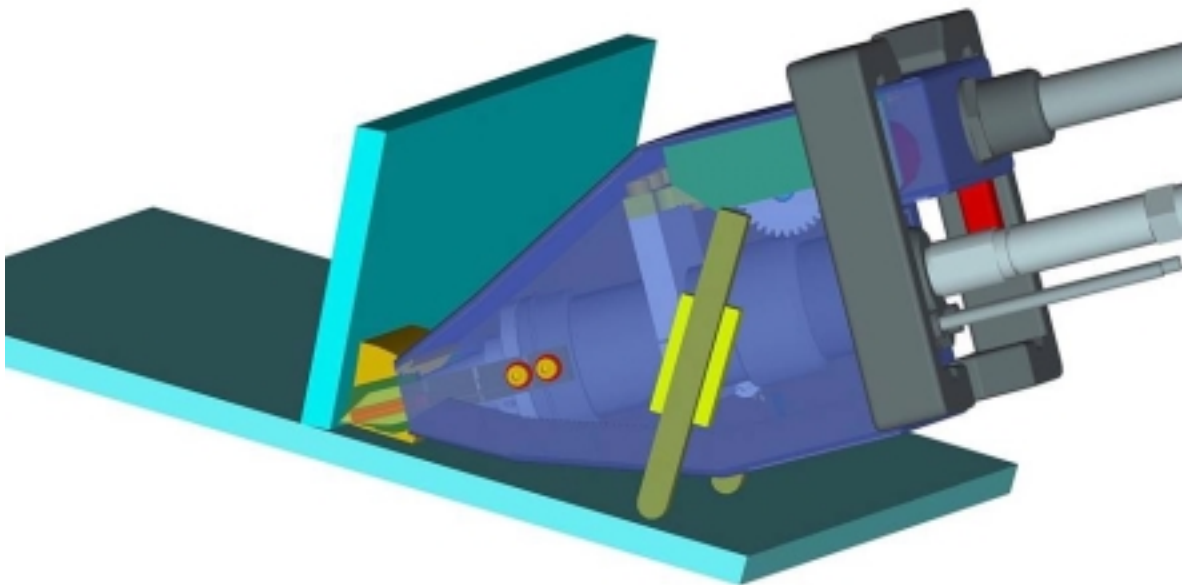

Figure 4: Tool concept for short tack welds
Source: SLV Halle

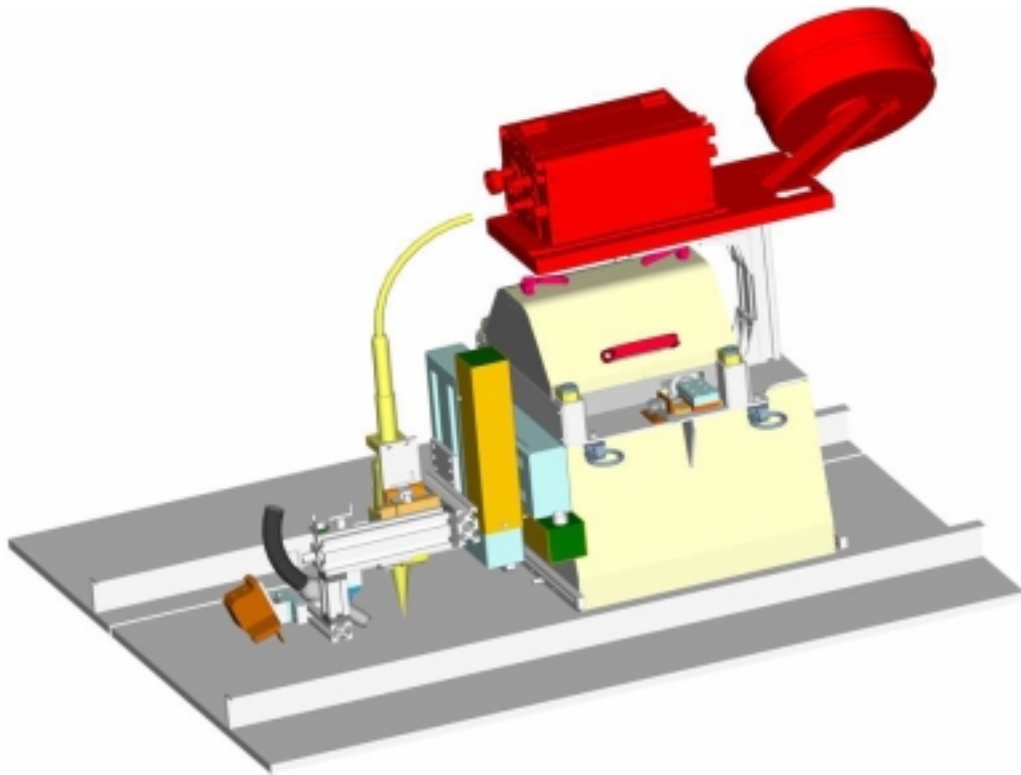

Figure 5: Schematic representation of a tractor for long linear butt welds.
Source: Fronius

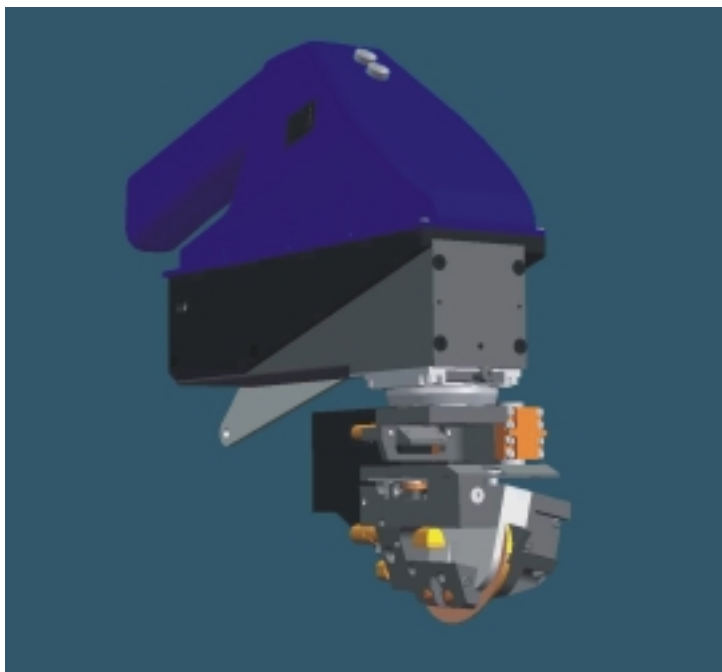

Figure 6: Modular laser welding head for welding and cutting adapted to shipbuilding applications by the DockLaser project
Source: Mobile Laser Tec